

ASSEMBLY INSTRUCTIONS

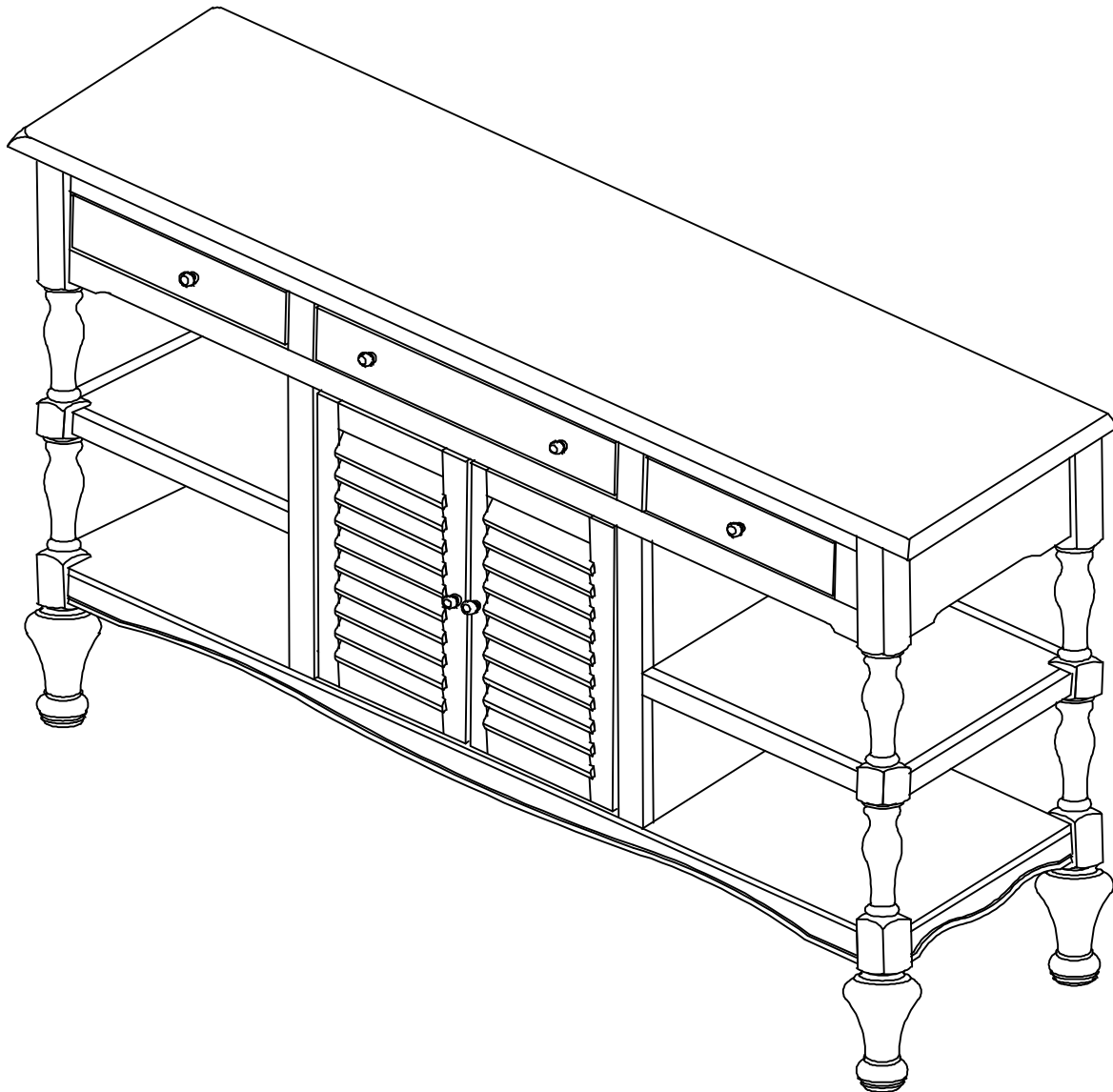

Description : OLDE WORLD SERVER
Item No. : SV-39

ITEM NO.: SV - 39
REVISED JAN 22, 2013

Printed in Vietnam

BEFORE ASSEMBLY

Thank you for purchasing this quality product. This product has been designed for easy assembly and constructed for durability. All parts were checked prior to packaging to insure quality. Prior to beginning assembly, however, make sure all parts and hardware are included and free of obvious defect. If a part is missing or defective, please contact the store where purchased. If hardware is missing, or you need help with assembly, please call toll free 888-944-8396.

IMPORTANT NOTE:

- Place all wooden parts on a clean and smooth surface such as a rug or carpet to avoid the parts from being scratched.
- Remove all wrapping material, including staples & packing straps before you start to assemble.
- DO NOT tighten all screws and bolts until completely assembled.
- Keep all hardware parts out of reach of children.



ASSEMBLY TOOLS REQUIRED

NOT INCLUDED

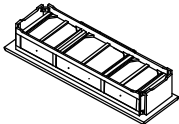
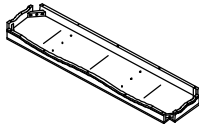

PART LIST SV – 39A

When unpacking, please be careful not to discard any parts with the packaging. Before continuing, please make sure you have the following parts:

NO	Description	Qty	Sketch	NO	Description	Qty	Sketch
A	Table top	1		B	Bottom panel	1	
C	Leg	4					





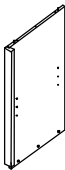
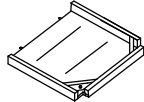
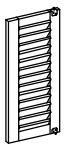
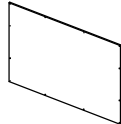
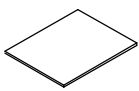







PART LIST SV – 39B

When unpacking, please be careful not to discard any parts with the packaging. Before continuing, please make sure you have the following parts:

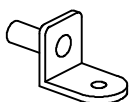
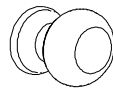
NO	Description	Qty	Sketch	NO	Description	Qty	Sketch
D	Side panel (L – R)	2		E	Side shelf	2	
F	Door (L – R)	2		G	Back panel	1	
I	Center shelf	1					

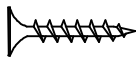
HARDWARE LIST

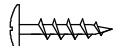
When unpacking, please be careful not to discard any parts with the packaging. Before continuing, please make sure you have all of the following hardware:

NO	Description	Qty	Sketch	NO	Description	Qty	Sketch
1	Short bolt (M6x30mm)	12		2	Long bolt (M6x50mm)	8	
3	Hexagon nut (M8x7mm)	8		4	Flat washer (Φ8.5 x 19mm)	8	
5	Lock washer (Φ8.5 x 13mm)	8		6	Flat Washer (Φ6.5 x 19mm)	20	
7	Lock Washer (Φ6.5 x 11mm)	20		8	Shelf support bracket	4	
9	Knob (Φ35x30mm)	6		10	Pan head screw (M4x30mm)	6	
11	Door pin (Φ5.2/Φ13x1.2mm) (Φ7x10mm)	4		12	Long screw (M4x30mm)	1	
13	Steel band	1		14	Screw (M3.5 x15mm)	6	
15	Screw (M3.5 x15mm)	12		16	Warning label	3	<p style="text-align: center; margin: 0;">WARNING!</p> <p style="text-align: center; margin: 0; font-size: small;">THIS ITEM IS PRONE TO TIPPING.</p> <p style="text-align: center; margin: 0; font-size: x-small;">USE ANTI-TIPPING HARDWARE (PROVIDED) TO SECURE TO THE WALL.</p> <p style="text-align: center; margin: 0; font-size: x-small;">DO NOT ALLOW CHILDREN TO CLIMB ON FURNITURE.</p> <p style="text-align: center; margin: 0; font-size: x-small;">PLAC HEAVIEST OBJECTS IN LOWER DRAWERS.</p> <p style="text-align: center; margin: 0; font-size: x-small;">DO NOT OPEN MORE THAN ONE DRAWER ON THE UNIT AT THE SAME TIME.</p>
17	Allen Key (4x80mm)	1		18	Wrench (13mm)	1	

NOTE: PACKED IN CARTON SV-39B

STEP 1

Attach side panel (D) to top (A) with bolts (1), washers (6) and (7) as shown below. Tighten with allen key (17).

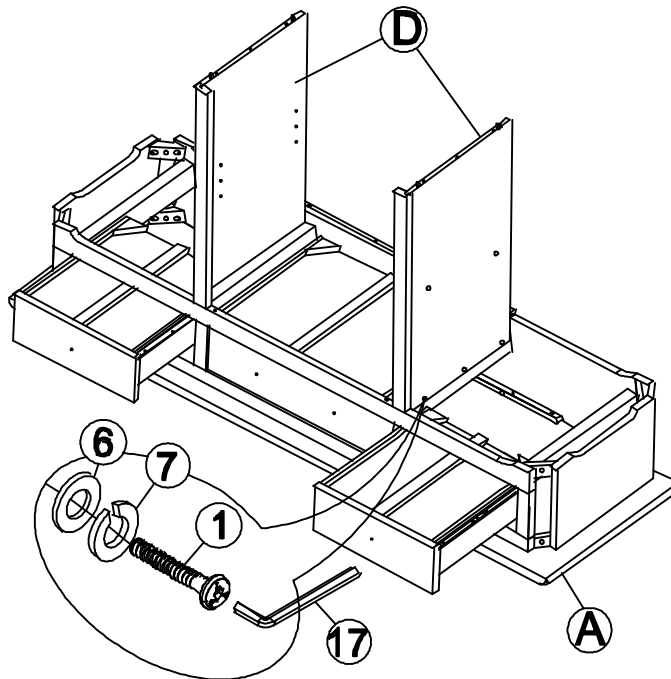

STEP 2

Attach doors (F) (from STEP 1) to top (A) and bottom (B) with door pins (11). Attach bottom panel (B) to side panel (D) with bolts (1) and washers (6) and (7) as shown below. Tighten with allen key (17).

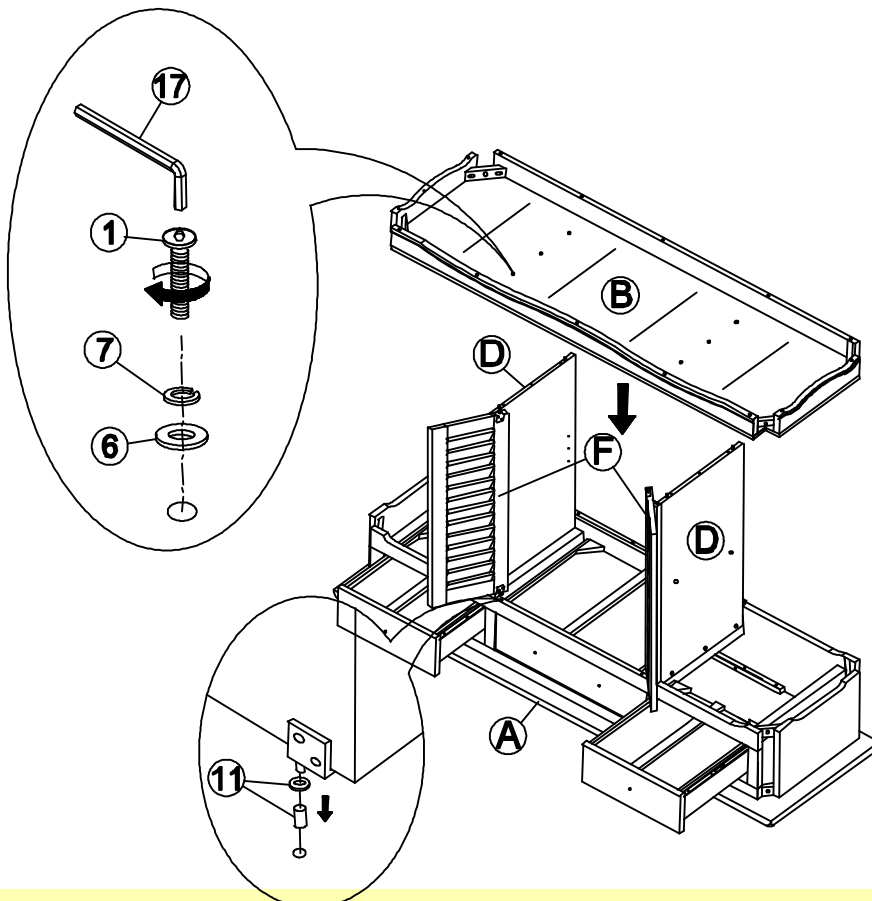

STEP 3

Position the side shelf (E) to side panel (D) as shown below.

Attach legs (C) to top (A) with washers (4) and (5), and nuts (3). Tighten with the wrench (18).

Attach legs (C) to side shelf (E) and bottom panel (B) with bolts (2) and washers (6) and (7) as shown below. Tighten with allen key (17).

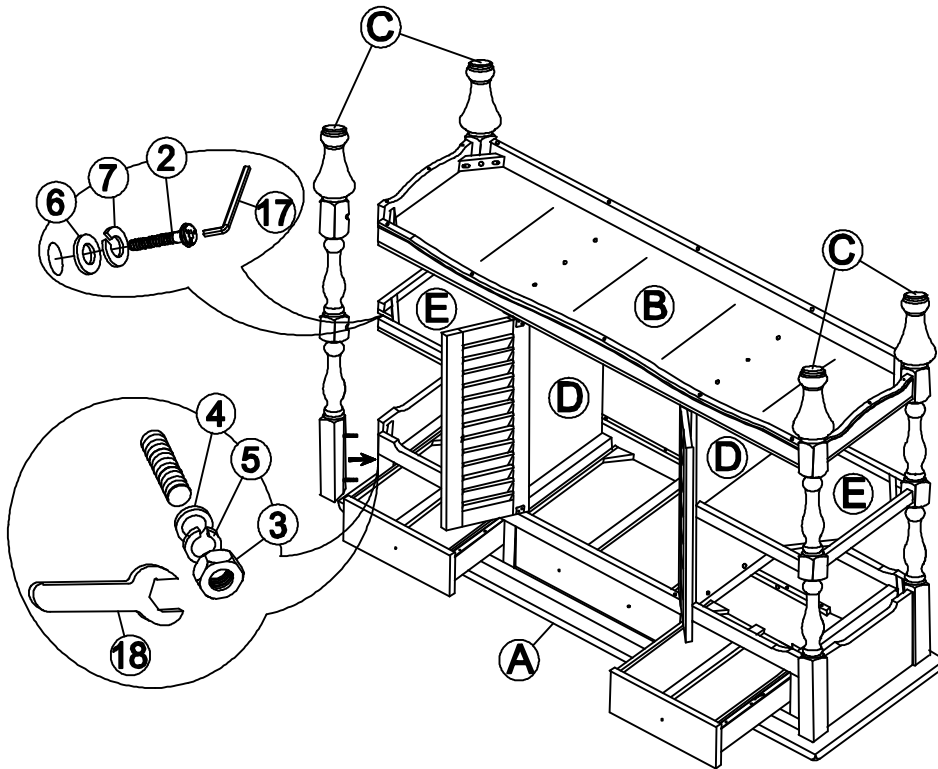

STEP 4

Attach back panel (G) with screws (15). Tighten with a screwdriver.

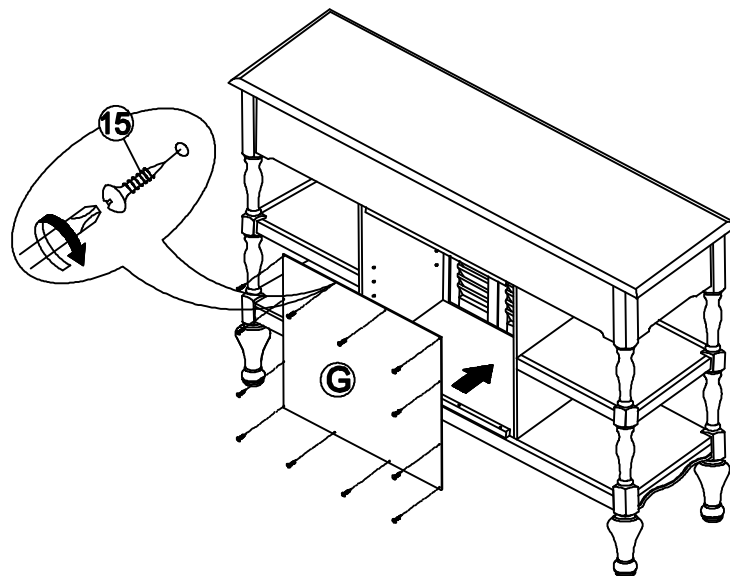

STEP 5

Place the center shelf (I) on the shelf support brackets (8) and secure with screws (14) as shown below. Tighten with a screwdriver.

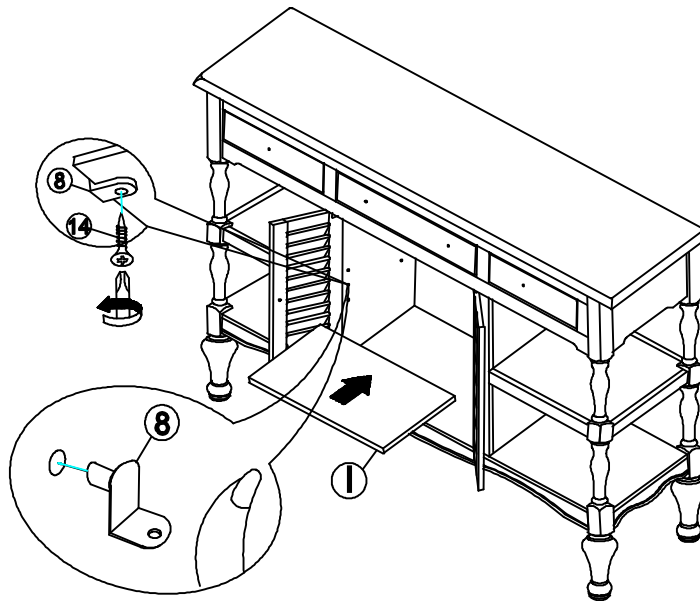

STEP 6

Attach knobs (9) to front of drawers and doors (F) with screws (10). Tighten with a screwdriver. Stick the Warning labels (15) on side of drawers before use.

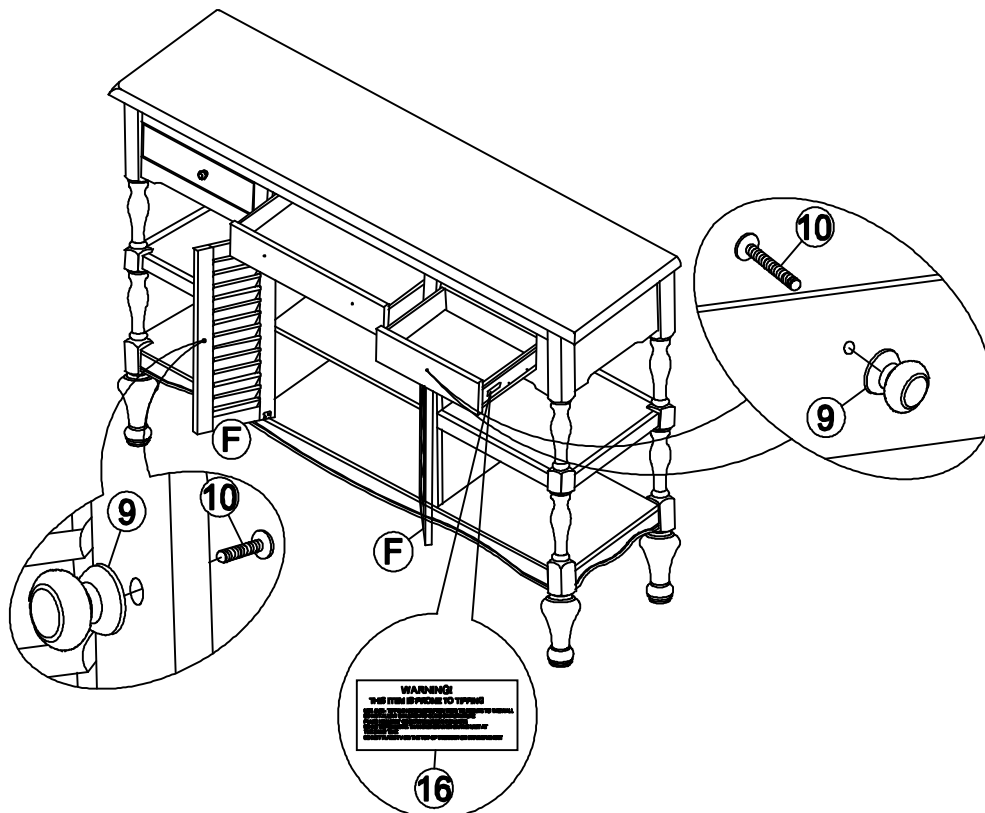

STEP 7

Attach steel band (13) to the unit with screws (14). Then attach the steel band to a wall with screw (12) as shown below (to secure the product and prevent tipping).

